

AFCO Industries, Inc.

Aluminum Products

WRAPPING ROUND COLUMN AROUND AN EXISTING POST ASSEMBLY & INSTALLATION INSTRUCTIONS

SIZE CHART

AFCO ROUND COLUMN SIZE	No. of Staves Per Column	Max. size of existing round post (Diameter)	Max. Size of Existing Square Post (Diameter)
6"	3	4 1/2"	3 1/2"
8"	3	6 1/4"	4 1/2"

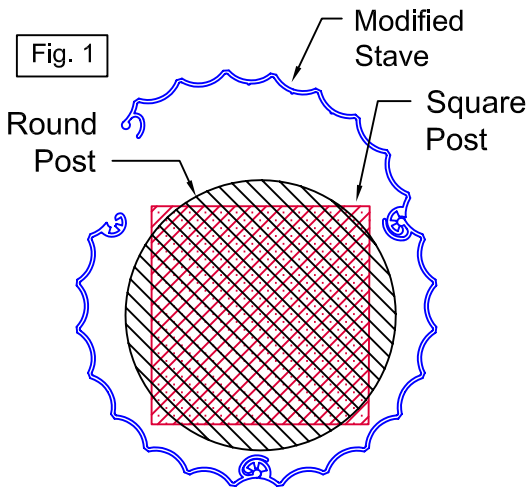

Step 1. Measure height of existing post and cut column staves with a saw.

Step 2. Join staves together around the existing post, adding the modified stave last (Fig. 1).

Note that the modified stave has 3 Identification marks and shorter inter-locking lip as shown (Fig. 2).

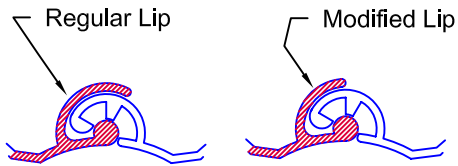

Join section together, small hooks curling into large hooks.

Fig. 2

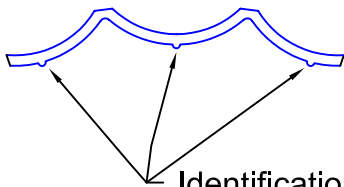

Identification Marks on the Modified Stave

Step 3. Locate L-shaped brackets around column at top and bottom and secure with screws (Fig. 3).

Step 4. Remove one screw from each side of Cap and Base. Then, place them around the column and re-insert the screw as shown (Fig. 4).

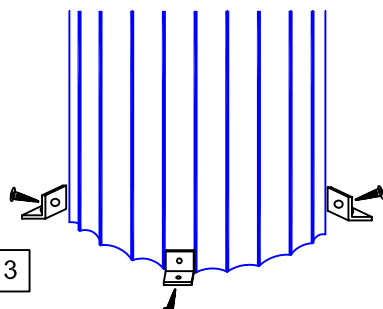

Fig. 3

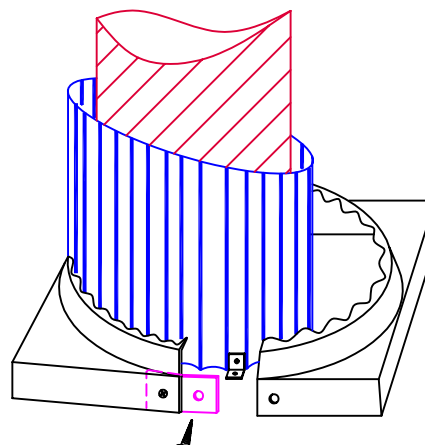
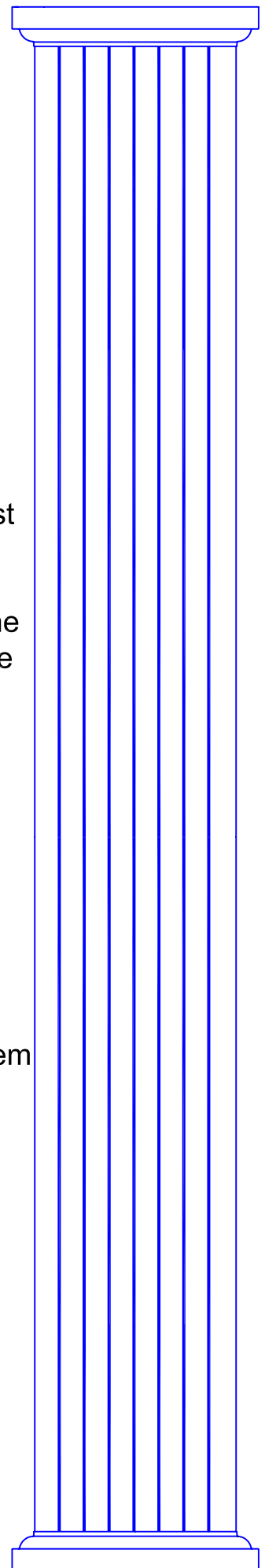

Fig. 4



COLUMNS MODIFIED FOR WRAP AROUND APPLICATION ARE NON LOAD BEARING.